

July 22, 2024

ADDENDUM NO.01 to the plans and specifications for the Macomb County, 2024 Paving Projects, Various Sites, Mt. Clemens, MI, Architect's Project No. 242034, dated July 1, 2024.

The above plans and specifications are modified, supplemented or augmented as follows, and this ADDENDUM NO. 01, is hereby made a part of the contract documents.

Specification Section 01100, Revised Bid Form, Cover Sheet and Drawings AS1.0, AS3.0 & AS4.0 are being issued with this Addendum.

ARCHITECTURAL ITEMS

ITEM NO. 1: Attached are the questions due July 18, 2024 with the answers.
RFB 11-24 - QUESTIONS AND ANSWERS

1. Could you please confirm the correct number and specific locations of the project sites? In the spec document, it is indicated that there are six areas for the project, only four locations are mentioned and the map within the same drawing document displays seven different sites.

Refer to the revised and reissued Cover Sheet and Bid Form. All locations to be bid separately and also as a combined bid. Bidders must bid all sites and alternate as shown on the Bid Form.

2. Does this project have any wage requirements? Prevailing wage or Davis Bacon wages? **No**
3. Who is responsible for testing fees? GC or Owner? **Owner**

ITEM NO. 2: Attached refer to the revised and reissued Bid Form. Bidders are to completely fill out the form. Segregated bids will not be considered.

ITEM NO. 3: Revised Sheets:

1. Cover Sheet, revised locations.
2. Sheet AS1.0
 - a. Added concrete replacement at walk to Health Dept. as shown and associated concrete details. Provide ADA cast in place detectable warning surface at concrete edge to asphalt parking.
 - b. Added Alternate #1 as shown.
3. Sheet AS3.0
 - a. Added Alternate #1 as shown.
4. Sheet AS4.0
 - a. Added replacement of concrete at circular flagpole area as indicated.

END OF ADDENDUM NO. 01

Cc: Mary Schultz, Macomb County
Benjamin Treppa, Macomb County
Anthony Torelli, Macomb County
Ron Syme, Wakely Associates

SECTION 01100 - ALTERNATES

PART 1 - GENERAL

1.01 RELATED DOCUMENTS:

- A. Attention is directed to Division 0, Bidding and Contract Requirements, and to Division 1, General Requirements, which are hereby made a part of this Section.

1.02 DESCRIPTION OF WORK:

- A. This section identifies each Alternate by number, and describes the basic changes to be incorporated into the work, only when the Alternate is made a part of the work by specific provisions in the Owner-Contractor Agreement.
- B. Alternate schedule below is part of the Bidding Documents and will be considered in selection of Contractors and awarding contracts.
- C. Unless otherwise provided, Owner will accept or reject alternates within one hundred twenty (120) days of date of contract. Owner reserves the right to reject any or all alternates.

1.03 ALTERNATES:

A. General:

- 1. The descriptions for each alternate listed in the schedule are primarily scope definitions, and do not necessarily detail the full range of materials and processes needed to complete the work as required.
- 2. Refer to applicable specification sections (Division 2 through 12), and to applicable drawings, for specific requirements of the work, regardless of whether references are so noted in description of each alternative.
- 3. Coordinate pertinent related work and modify surrounding work as required to properly integrate the work under each Alternate, and to provide the complete construction required by Contract Documents.
- 4. Referenced sections of specifications stipulate pertinent requirements for products and methods to achieve the work stipulated under each Alternate.

MACOMB COUNTY
2024 PAVING PROJECTS
VARIOUS SITES

242034

JULY 1, 2024

B. Schedule:

1. **Alternate No. 1:**
Work indicated as an Alternate on Sheets AS1.0 & AS3.0.

END OF SECTION 01100

**BID ITEM #11-24
MACOMB COUNTY
2024 PAVING PROJECTS-VARIOUS SITES**



BID FORM

**Bid Item #11-24
Macomb County**
2024 Paving Projects
Various Sites

Bidder: _____
(print or type company name)

County of Macomb
Mount Clemens, Michigan

OWNER _____
(Telephone Number)

MACOMB COUNTY
MT. CLEMENS, MICHIGAN 48043

ARCHITECT
WAKELY ASSOCIATES INC.
30500 VAN DYKE AVENUE, SUITE 209
WARREN, MI 48093

GENERAL AGREEMENTS

- A. The Bidder acknowledges that he/she has had the opportunity to examine the site and locality where the Work is to be performed and has become familiar with the legal requirements, laws, rules, regulations and conditions affecting the cost, progress and performance of the Work; and has made such independent investigations as Bidder deemed necessary to prepare the Bid. Further, Bidder hereby states that the Base Bid set forth in this Bid Response is true and correct.
- B. The Bidder agrees that this Bid shall not be withdrawn for a period of 30 calendar days after the scheduled closing time for receiving Bids.
- C. The Bidder declares that in preparing this Bid, Bidder is assured of the availability of all labor, materials and products to meet the substantial completion date.
- D. The Bidder acknowledges that the price stated below includes all taxes of whatever character or description.
- E. The Bidder agrees to execute a Contract for work covered by this Bid, provided that he/she be notified of its acceptance within thirty (30) days after the opening of Bids.

SCHEDULE - TIME OF COMPLETION

The undersigned agrees to commence the Work of the Contract Documents on a date specified in a written "Notice to Proceed", and shall fully complete the Work within the required time allowed. Owner requires work to be substantially complete no later than September 27, 2024. The proposed Bid is in full consideration of this.

ACKNOWLEDGEMENT OF ADDENDA

The Bidder acknowledges receipt of and use of the following Addenda in the preparation of this Bid:

Addendum No. 1, dated _____, Addendum No. 3, dated _____
Addendum No. 2, dated _____, Addendum No. 4, dated _____

**BID ITEM #11-24
MACOMB COUNTY
2024 PAVING PROJECTS-VARIOUS SITES**



BID FORM SUPPLEMENTS

Attached to this Bid Form and incorporated herein are the following documents, completed in full by the undersigned:

Base Bid Form Supplement – Unit Prices/Supplemental Fees

BASE BID

The undersigned Bidder, having carefully examined the Bidding and Contract Requirements, Conditions of the Contract, Drawings, Specifications, and all subsequent Addenda, all as issued by the Owner, and being familiar with all conditions and requirements of the Work, hereby proposes and agrees to furnish all material, labor, equipment, tools and supervision; and to furnish all services necessary to complete the Work required in accordance with the Bidding Documents for the following projects, in the following amount:

BASE BID – COMBINED (All 6 Buildings):

_____ Dollars \$ _____
(Sum to be written out)

Note: Bidder acknowledges that the above bid includes a \$50,000 contingency.

BASE BID – MACOMB COUNTY JAIL SITE: MC Jail Parking & MC Health Dept. (All work shown on Sheet AS1.0)

_____ Dollars \$ _____
(Sum to be written out)

Note: Bidder acknowledges that the above bid includes a \$15,000 contingency.

BASE BID – ROBERT A. VERKUILEN BUILDING: Verkuilen Bldg & MC Public Works (Refer to Sheet AS2.0)

_____ Dollars \$ _____
(Sum to be written out)

Note: Bidder acknowledges that the above bid includes a \$10,000 contingency.

**BID ITEM #11-24
MACOMB COUNTY
2024 PAVING PROJECTS-VARIOUS SITES**



BASE BID – MC 42ND DISTRICT COURT-DIVISION II: (Refer to Sheets AS4.0, M0.0 & P1.00)

_____ Dollars \$ _____
(Sum to be written out)

Note: Bidder acknowledges that the above bid includes a \$15,000 contingency.

BASE BID – MACOMB COUNTY ADMINISTRATION BUILDING PARKING DECK (Refer to Sheets AS5.0, AS5.1, AS5.2 & AS5.3)

_____ Dollars \$ _____
(Sum to be written out)

Note: Bidder acknowledges that the above bid includes a \$10,000 contingency.

ALTERNATES

One Alternate is being priced. As follows:

Alternate No. 1: Cost for work indicated as an Alternate on Sheets AS1.0 & AS3.0.

ALTERNATE NO. 1: _____

Dollars \$ _____ (sum to be written out)

**BID ITEM #11-24
MACOMB COUNTY
2024 PAVING PROJECTS-VARIOUS SITES**



VOLUNTARY ALTERNATES

The following voluntary alternates are offered by the Bidder. The undersigned agrees that the amounts indicated below shall be added to or deducted from the Base Bid, as the case may be for each alternate which is accepted.

Description of Voluntary Alternates	Add	Deduct
1. _____	\$ _____	\$ _____
2. _____	\$ _____	\$ _____
3. _____	\$ _____	\$ _____
4. _____	\$ _____	\$ _____

Respectfully submitted this ____ day of _____, 20____.

By: _____
(Name of bidding firm or corporation)

Witness:

By: _____
(Signature)

Attest: _____
(Signature)

(Type or print name)

By: _____
(Type or print name)

Title: _____
(Owner/Partner/President/Vice Pres.)

Title: _____
(Corporate Secretary or Assistant Secretary Only)

Address: _____
Phone: _____

License: _____

Federal ID No.: _____

(Affix Corporate Seal Here)

Company Name

Company Representative

Title

Date

**BID ITEM #11-24
MACOMB COUNTY
2024 PAVING PROJECTS-VARIOUS SITES**



BID FORM SUPPLEMENT - UNIT PRICES/SUPPLEMENTAL FEES

This form is required to be attached to the Base Bid Form.

Bid Item #11-24
Macomb County
2024 Paving Projects
Various Sites

Bidder: _____
(print or type company name)

County of Macomb
Mount Clemens, Michigan

UNIT PRICES

Unit Price 1A: Additional 4" concrete removal and replacement per square foot that may exceed the quantities given on the documents. Such unit price to include the cost of material and earthwork preparation required and related work where applicable, including OH&P, insurance, bond and taxes.

ADD _____ Dollars/Sq. Foot(\$ _____ per s.f.)

Unit Price 1B: Additional 6" concrete removal and replacement per square foot that may exceed the quantities given on the documents. Such unit price to include the cost of material and earthwork preparation required and related work where applicable, including OH&P, insurance, bond and taxes.

ADD _____ Dollars/Sq. Foot(\$ _____ per s.f.)

Unit Price 1C: Additional 8" concrete removal and replacement per square foot that may exceed the quantities given on the documents. Such unit price to include the cost of material and earthwork preparation required and related work where applicable, including OH&P, insurance, bond and taxes.

ADD _____ Dollars/Sq. Foot(\$ _____ per s.f.)

Unit Price 2A: Expansion joint backing rod and sealant per lineal foot, which may exceed the quantities given on documents or unforeseen areas which may require sealant. Such unit price to include the cost of materials, preparation required and related work where applicable, including OH&P, insurance, bond and taxes.

ADD _____ Dollars/l.ft.(\$ _____ per l.ft.)

Unit Price 3A: Amount per cubic yard for removal off site and legal disposal of existing unsuitable soils, and/or existing base, including OH&P, insurance, bond and taxes.

ADD _____ Dollars/c.y.(\$ _____ per c.y.)



**BID ITEM #11-24
MACOMB COUNTY
2024 PAVING PROJECTS-VARIOUS SITES**

Unit Price 3B: Amount per cubic yard for additional amounts of 21AA limestone installed beyond that indicated on drawings, including OH&P, insurance, bond and taxes.

ADD _____ Dollars/c.y.(\$ _____ per c.y.)

Unit Price 3C: Amount per square yard to install Tensar Triax tx160 grid-min. 2' overlap-includes pinning, including OH&P, insurance, bond and taxes.

ADD _____ Dollars/s.y.(\$ _____ per s.y.)

SUPPLEMENTAL FEES

For additional work performed upon instruction of Macomb County, by Sub-Contractors of the Undersigned, add to the Sub-Contractor's prices for such work a fee of _____%, which includes all the charges of the undersigned for overhead and profit.

Any additional work performed upon instruction of Macomb County by persons other than the Sub-Contractors of the undersigned, the charges will be actual cost of the labor, and materials, (less all discounts) plus the fee of _____%, which includes all the charges of the undersigned for overhead and profit, and to which shall be added the actual cost of insurance & taxes.

Each Bid covering extra work, shall be accompanied with complete itemized material & labor breakdowns.

For all revisions involving the deletion of contract work, it is agreed that the full credit shall be given Macomb County for such work deleted, including overhead and profit as quoted hereinbefore.

NEGOTIATION

The undersigned agrees that, should the overall cost exceed the funds available, he/she will be willing to negotiate with Macomb County and Architect; for the purpose of making further reductions in the Contract work, and shall agree to give full credit for all such reductions in the work requested by Macomb County, including full value of labor, materials, and Sub-Contract work and reasonable proportionate reductions in overhead and profit, thereby arriving at an agreed upon Contract price.

Submitted this ___ day of _____, 20 ____

By: _____
(Name of bidding firm or corporation)

By: _____
(Signature)

(Type or print name)

Title: _____
(Owner/Partner/President/Vice Pres.)

**BID ITEM #11-24
MACOMB COUNTY
2024 PAVING PROJECTS-VARIOUS SITES**



BID FORM SUPPLEMENT - LIST OF SUB-CONTRACTORS

All sealed bids for construction contracts shall provide a list of preferred sub-contractors and identify, with documentation, whether each subcontractor is a County-based Enterprise.

NAME OF BIDDER: _____

NAME OF SUB-CONTRACTOR _____

CONTACT PERSON _____

ADDRESS _____

TELEPHONE NO. _____

MACOMB COUNTY BASED ENTERPRISE (Y/N) _____

NAME OF SUB-CONTRACTOR _____

CONTACT PERSON _____

ADDRESS _____

TELEPHONE NO. _____

MACOMB COUNTY BASED ENTERPRISE (Y/N) _____

NAME OF SUB-CONTRACTOR _____

CONTACT PERSON _____

ADDRESS _____

TELEPHONE NO. _____

MACOMB COUNTY BASED ENTERPRISE (Y/N) _____

NAME OF SUB-CONTRACTOR _____

CONTACT PERSON _____

ADDRESS _____

TELEPHONE NO. _____

MACOMB COUNTY BASED ENTERPRISE (Y/N) _____

**BID ITEM #11-24
MACOMB COUNTY
2024 PAVING PROJECTS-VARIOUS SITES**



**COUNTY OF MACOMB
VENDOR CERTIFICATION DEBARMENT**

All information requested in this section must be completed and the document notarized. Any information omitted, or erroneously reported, may result in disqualification for current or future bidding and supply on behalf of the County of Macomb.

The undersigned warrants and presents that they have full complete authority to make representations for and on behalf of the undersigned company and that their representations are fully binding upon the undersigned company.

1. The undersigned are not presently debarred, suspended, proposed for debarment, declared ineligible, or excluded from transactions by any federal department or agency, or any state, county or local municipality, department or agency.
2. The undersigned has not within a three (3) year period preceding this bid been convicted of, or had a civil judgment rendered against them for the commission of fraud, a criminal offense in connection with obtaining, attempting to obtain, or performing a public (federal, state or local) transaction, or a contract a public transaction, violation of federal or state antitrust statutes, or commission of embezzlement, theft, forgery, bribery, falsification or destruction of records, making false statements, or receiving stolen property.
3. The undersigned are not presently indicted for or otherwise criminally or civilly charged by any governmental entity (federal, state or local) with commission of any of the offenses set forth in paragraph 2.
4. The undersigned have not within a three (3) year period preceding this bid, had one or more public transactions (federal, state or local) terminated or attempted to be terminated for cause or default.

IF THE APPLICANT IS UNABLE TO CERTIFY TO ANY OF THE STATEMENTS IN THIS CERTIFICATION, CERTIFICATION AND EXPLANATION SHALL BE ATTACHED AND PRESENTED WITH THIS CERTIFICATION.

THE UNDERSIGNED CERTIFIES OR AFFIRMS THE TRUTHFULNESS AND ACCURACY OF THE CONTENTS OF THE STATEMENTS SUBMITTED MADE ON BEHALF OF THE UNDERSIGNED BIDDER.

Bidder: _____

Bidder Address: _____

Applicant/Bidder Representative: _____

Signature: _____
(Print full name)

Subscribed and sworn to before me this
_____ day of _____, 20__.

Notary Public
County of _____,
State of _____
My Commission expires: _____

**BID ITEM #11-24
MACOMB COUNTY
2024 PAVING PROJECTS-VARIOUS SITES**



GOOD HOUSEKEEPING AND BEST MANAGEMENT PRACTICES

Bidder shall comply with the Good Housekeeping and Best Management Practices as outlined in SEMCOG's LID that can be found at:

<https://semcog.org/Reports/LID/files/assets/basic-html/page-1.html#>.

Where applicable, Bidder to annually certify their trucks and tanks to ensure that materials extracted stay within the truck until it reaches the permitted disposal site.

All equipment utilized in the cleaning process will abide by manufacturers recommendations.

Initial

Date



MACOMB COUNTY EXECUTIVE MACOMB COUNTY PAVING 2024 PAVING PROJECTS VARIOUS SITES

LOCATIONS:

- MACOMB COUNTY JAIL
- MACOMB COUNTY HEALTH DEPARTMENT
- ROBERT A. VERKUILEN BUILDING
- DEPARTMENT OF PUBLIC WORKS
- 42nd DISTRICT COURT - NEW BALTIMORE
- MACOMB COUNTY ADMINISTRATION PARKING DECK

ISSUED FOR: Bids
 DATE: JULY 1, 2024 (ADDENDUM #1: JULY 22, 2024)
 PROJECT NO.: 242034

ARCHITECT:

WAKELY ASSOCIATES, INC./ ARCHITECTS
 30500 VAN DYKE AVE, SUITE 209, WARREN, MI 48093, 586-573-4100

Index of Drawings	
ARCHITECTURAL DRAWINGS:	
G0.0	COVER SHEET, SHEET INDEX, LOCATION MAPS
AS1.0	MC JAIL SITE - ARCHITECTURAL SITE PLAN
AS2.0	DEPT. OF PUBLIC WORKS & VERKUILEN BUILDING - ARCHITECTURAL SITE PLAN & DETAILS
AS3.0	HEALTH DEPT. BUILDING - ARCHITECTURAL SITE PLAN & DETAIL
AS4.0	42nd DISTRICT COURT - NEW BALTIMORE
AS5.0	MC ADMINISTRATION BUILDING - PARKING DECK DEMO
AS5.1	MC ADMINISTRATION BUILDING - RESTRIPING PLAN
AS5.2	MC ADMINISTRATION BUILDING - DETAILS
AS5.3	MC ADMINISTRATION BUILDING - DETAILS
M0.00	MECHANICAL GENERAL INFORMATION
P1.00	SITE PLUMBING DEMOLITION AND NEW WORK PLAN

NORTH
LOCATION MAP - CENTRAL CAMPUS

NORTH
LOCATION MAP - 42ND DIST. COURT - NEW BALTIMORE

Macomb County Paving, 2024 Paving Projects
 Issued for: Bids, Date: JULY 1, 2024 Project No.: 242034

GENERAL NOTES:

- NOTE TO THE CONTRACTOR(S): THREE (3) WORKING DAYS BEFORE YOU DIG, CALL MISS DIG TOLL FREE 1-800-482-7171 FOR UTILITY LOCATIONS ON THE GROUNDS.
- REMOVE EXISTING ASPHALT PAVING, CONCRETE, SIGNAGE AND VEGETATION AS REQUIRED TO COMPLETE NEW WORK AS SHOWN.
- COORDINATE WORK WITH MR. GARY NILSON OF MACOMB COUNTY FACILITIES & OPERATIONS, THREE (3) DAYS PRIOR TO COMMENCING.
- PROVIDE PROTECTION FOR FIXED EQUIPMENT AND VEGETATION DURING CONSTRUCTION. REPAIR AND/OR REPLACE EQUIPMENT OR MATERIAL DAMAGED DURING THE CONSTRUCTION OPERATION.
- MAINTAIN GENERAL DRAINAGE PATTERNS UNLESS NOTED OTHERWISE.
- THE CONTRACTOR SHALL CLEAN UP ALL DEBRIS AND MATERIALS RESULTING FROM HIS/HER OPERATION AND RESTORE ALL LAWN AREAS, PAVED SURFACES, STRUCTURES, DITCHES AND THE GENERAL AREA TO ITS ORIGINAL CONDITIONS.
- DO NOT SCALE DRAWINGS.
- RESTORE LAWN AREA PER SPECIFICATIONS.
- CONTRACTOR SHALL OBTAIN ALL PERMITS AS REQ'D BY THE CITY, TOWNSHIP, OR COUNTY INCLUDING R.O.W. PERMITS
- ALL EXISTING DIMENSIONS SHOWN ON PLANS ARE TO BE VERIFIED IN THE FIELD BY THE CONTRACTOR
- RE-STRIP REPAVED AREAS PER SPECS



WAKELY ASSOCIATES, INC.
ARCHITECTS & ENGINEERS
30500 VAN DYKE AVENUE
SUITE 209
WARREN, MICHIGAN 48093
PH: 586.573.4100
FX: 586.573.0822
EM: wa@wakelyga.com

**2024 MACOMB COUNTY PAVING
VARIOUS SITES**

ARCHITECTURAL SITE PLAN

- PRELIMINARY
- DESIGN DEVELOPMENT
- CONSTRUCTION
- FINAL RECORD

DRAWN BY: JMS
CHECKED BY: RAS

REVISIONS:
ADDENDUM #1 JULY 22, 2024

DATE: JULY 1, 2024
SHEET NO.:

AS1.0

JOB NO.: 242034

NEW WORK PAVING KEY

- SAWCUT, REMOVE, AND REPLACE EXISTING CONCRETE AND BASE
- SAWCUT, REMOVE, AND REPLACE EXISTING ASPHALT PAVING AND BASE
- CRACK FILL AND RESEAL ENTIRE PARKING LOT AS INDICATED

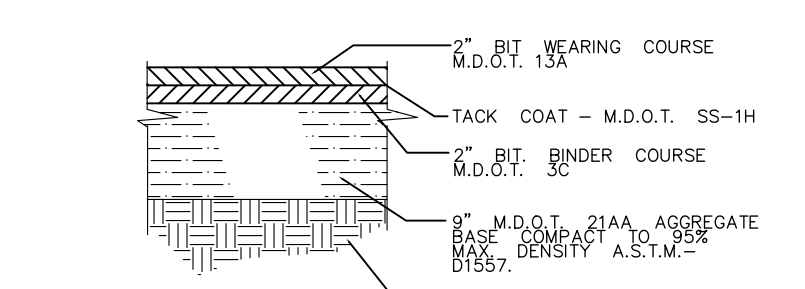
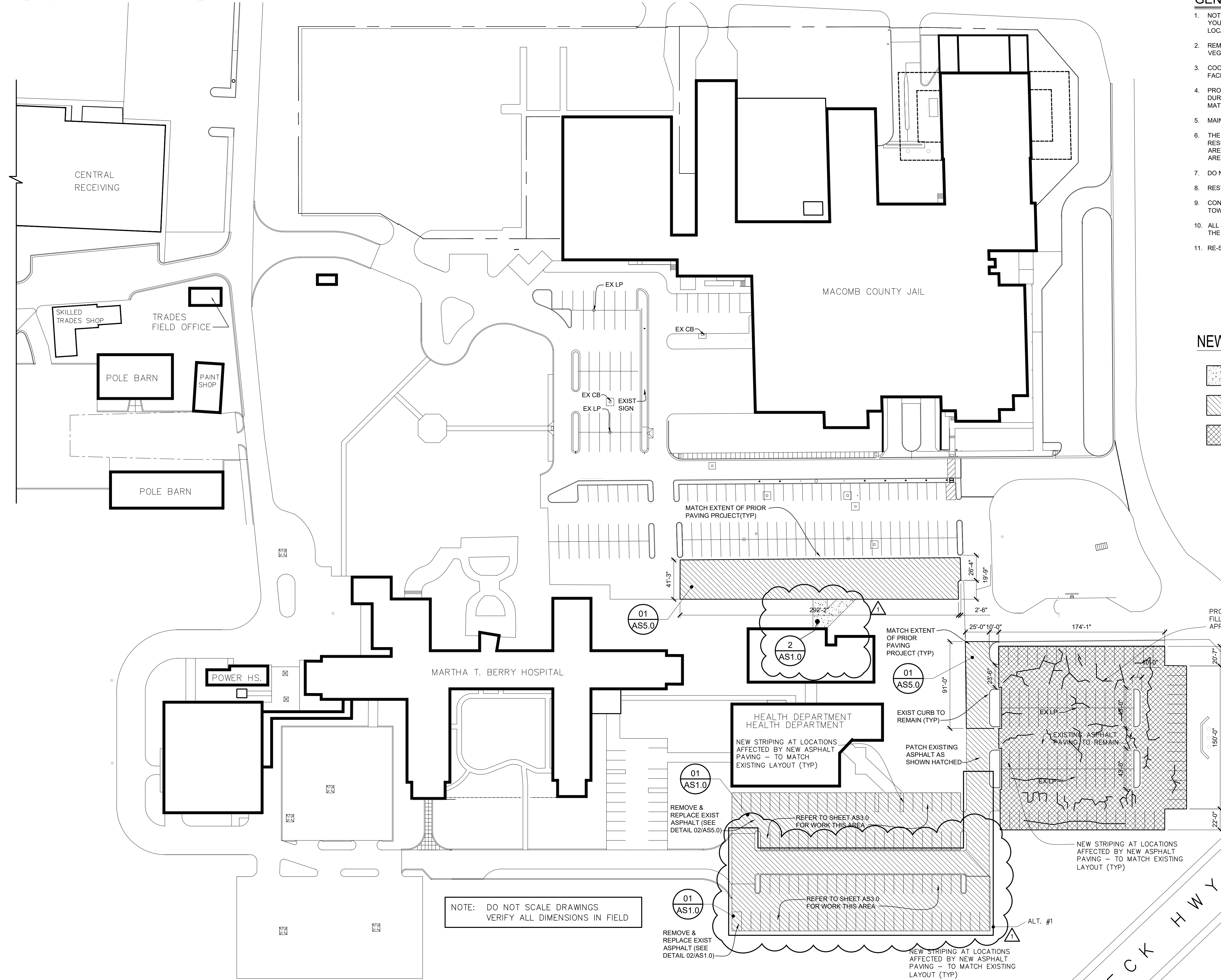

01 ASPHALT PAVING DETAIL
NO SCALE

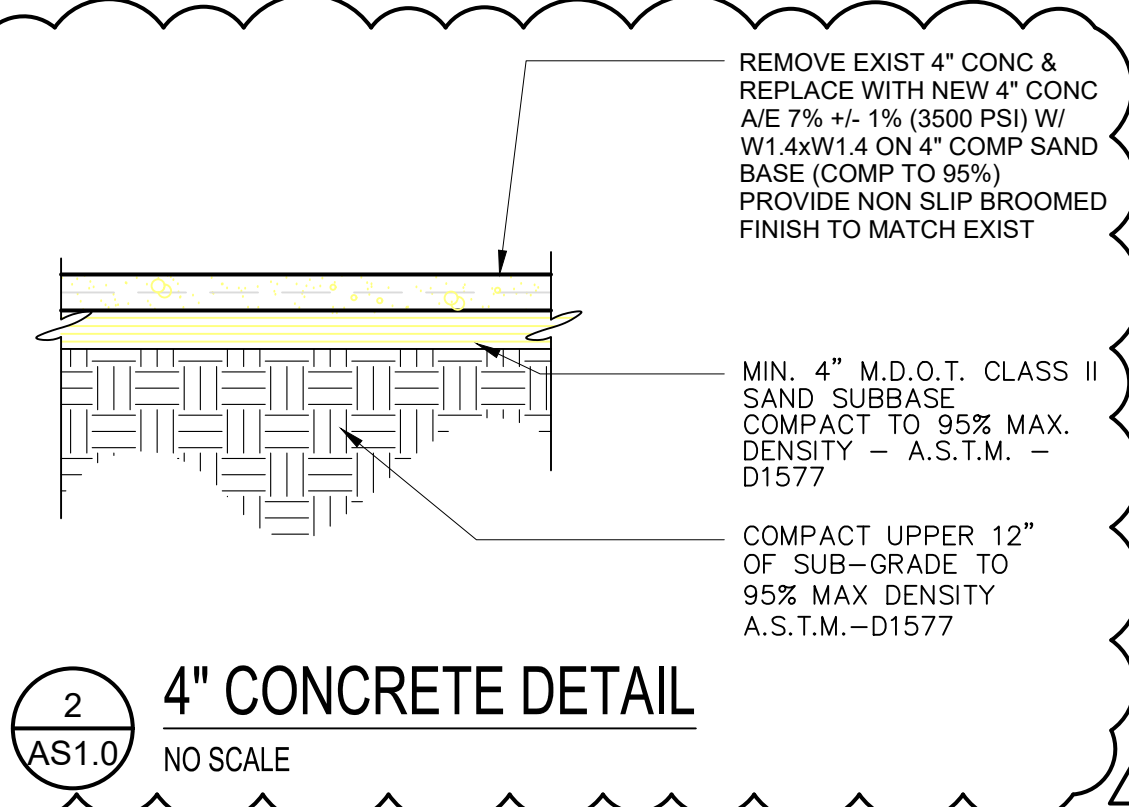

2 4\"/>

NOTE: DO NOT SCALE DRAWINGS
VERIFY ALL DIMENSIONS IN FIELD

**SITE PLAN
- MACOMB COUNTY JAIL CAMPUS**
SCALE: 1" = 50' - 0"

NOTE: DO NOT SCALE DRAWINGS
VERIFY ALL DIMENSIONS IN FIELD



GENERAL NOTES:

- NOTE TO THE CONTRACTOR(S): THREE (3) WORKING DAYS BEFORE YOU DIG, CALL MISS DIG TOLL FREE 1-800-482-7171 FOR UTILITY LOCATIONS ON THE GROUNDS.
- REMOVE EXISTING ASPHALT PAVING, CONCRETE, SIGNAGE AND VEGETATION AS REQUIRED TO COMPLETE NEW WORK AS SHOWN.
- COORDINATE WORK WITH MR. GARY NILSON OF MACOMB COUNTY FACILITIES & OPERATIONS, THREE (3) DAYS PRIOR TO COMMENCING.
- PROVIDE PROTECTION FOR FIXED EQUIPMENT AND VEGETATION DURING CONSTRUCTION. REPAIR AND/OR REPLACE EQUIPMENT OR MATERIAL DAMAGED DURING THE CONSTRUCTION OPERATION.
- MAINTAIN GENERAL DRAINAGE PATTERNS UNLESS NOTED OTHERWISE.
- THE CONTRACTOR SHALL CLEAN UP ALL DEBRIS AND MATERIALS RESULTING FROM HIS/HER OPERATION AND RESTORE ALL LAWN AREAS, PAVED SURFACES, STRUCTURES, DITCHES AND THE GENERAL AREA TO ITS ORIGINAL CONDITIONS.
- DO NOT SCALE DRAWINGS.
- RESTORE LAWN AREA PER SPECIFICATIONS.
- CONTRACTOR SHALL OBTAIN ALL PERMITS AS REQ'D BY THE CITY, TOWNSHIP, OR COUNTY INCLUDING R.O.W. PERMITS
- ALL EXISTING DIMENSIONS SHOWN ON PLANS ARE TO BE VERIFIED IN THE FIELD BY THE CONTRACTOR
- RE-STRIPPE REPAVED AREAS PER SPECS

NEW WORK PAVING KEY

- SAWCUT, REMOVE, AND REPLACE EXISTING CONCRETE AND BASE
- SAWCUT, REMOVE, AND REPLACE EXISTING ASPHALT PAVING AND BASE
- CRACK FILL AND RESEAL ENTIRE PARKING LOT AS INDICATED

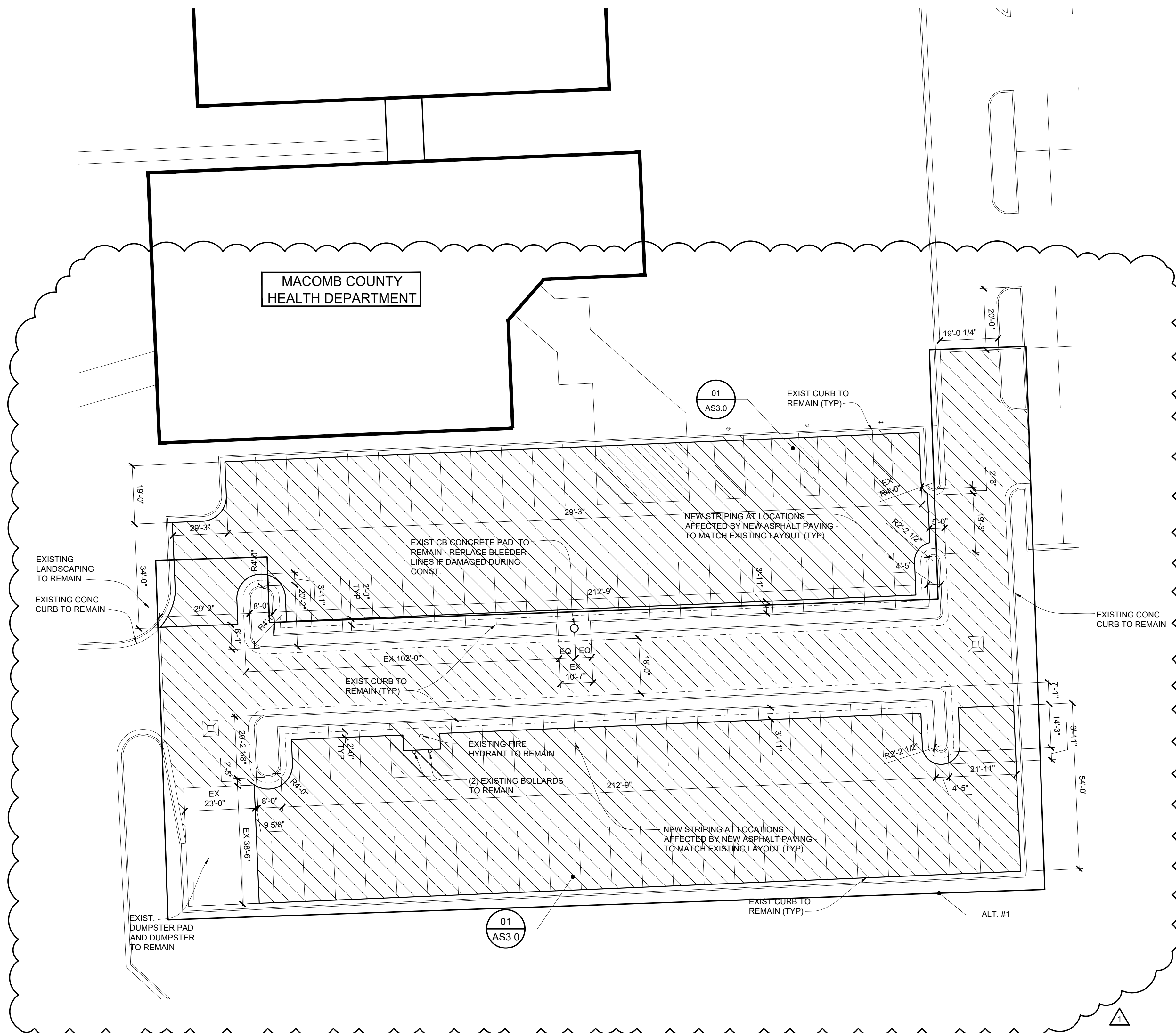

SITE PLAN
- MACOMB COUNTY HEALTH DEPARTMENT
SCALE: 1" = 50' - 0"

NOTE: DO NOT SCALE DRAWINGS
VERIFY ALL DIMENSIONS IN FIELD

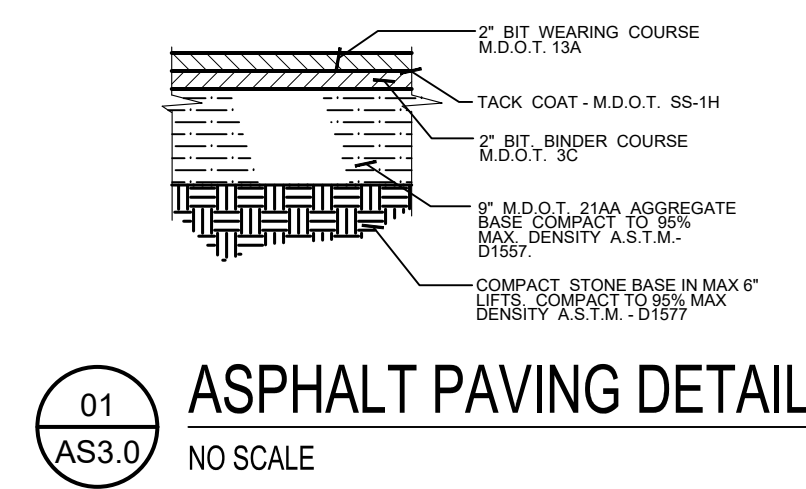

ASPHALT PAVING DETAIL
NO SCALE

2024 MACOMB COUNTY PAVING
VARIOUS SITES

HEALTH DEPARTMENT - PARTIAL SITE PLAN

PRELIMINARY
DESIGN DEVELOPMENT
CONSTRUCTION
FINAL RECORD

DRAWN BY: _____
CHECKED BY: _____

REVISIONS
ADDENDUM #1 JULY 22, 2024

DATE: JULY 1, 2024
SHEET NO.

AS3.0

JOB NO. 242034

GENERAL NOTES:

- NOTE TO THE CONTRACTOR(S) : THREE (3) WORKING DAYS BEFORE YOU DIG, CALL MISS DIG TOLL FREE 1-800-482-7171 FOR UTILITY LOCATIONS ON THE GROUND.
- REMOVE EXISTING ASPHALT PAVING, CONCRETE, SIGNAGE AND VEGETATION AS REQUIRED TO COMPLETE NEW WORK AS SHOWN.
- COORDINATE WORK WITH MR. GARY WILSON OF MACOMB COUNTY FACILITIES & OPERATIONS, THREE (3) DAYS PRIOR TO COMMENCING.
- PROVIDE PROTECTION FOR FIXED EQUIPMENT AND VEGETATION DURING CONSTRUCTION. REPAIR AND/OR REPLACE EQUIPMENT OR MATERIAL DAMAGED DURING THE CONSTRUCTION OPERATION.
- MAINTAIN GENERAL DRAINAGE PATTERNS UNLESS NOTED OTHERWISE.
- THE CONTRACTOR SHALL CLEAN UP ALL DEBRIS AND MATERIALS RESULTING FROM HIS/HER OPERATION AND RESTORE ALL LAWN AREAS, PAVED SURFACES, STRUCTURES, DITCHES AND THE GENERAL AREA TO ITS ORIGINAL CONDITIONS.
- DO NOT SCALE DRAWINGS.
- RESTORE LAWN AREA PER SPECIFICATIONS.
- CONTRACTOR SHALL OBTAIN ALL PERMITS AS REQ'D BY THE CITY, TOWNSHIP, OR COUNTY INCLUDING R.O.W. PERMITS
- ALL EXISTING DIMENSIONS SHOWN ON PLANS ARE TO BE VERIFIED IN THE FIELD BY THE CONTRACTOR
- RE-STRIPE REPAVED AREAS PER SPECS

LEGEND:

- SAWCUT & REMOVE EXISTING ASPHALT PAVING & BASE AND REPLACE W/ NEW ASPHALT PAVING & BASE AS INDICATED
- REMOVE EXIST 8" CONC. SLAB & REPLACE W/ NEW 8" CONC. SEE DETAIL 4/AS4.0
- SAWCUT & REMOVE EXISTING ASPHALT PAVING & BASE AND REPLACE W/ NEW CONCRETE PAVING & BASE
- CRACK FILL / SEAL EXISTING ASPHALT PAVING TO REMAIN - QTY'S AS INDICATED ON PLANS
- REMOVE EXIST 4" CONC WALK & REPLACE W/ NEW 4" CONC WALK - SEE DETAIL 02/AS1.0

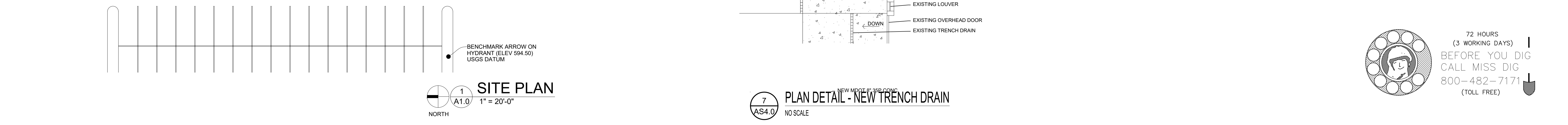
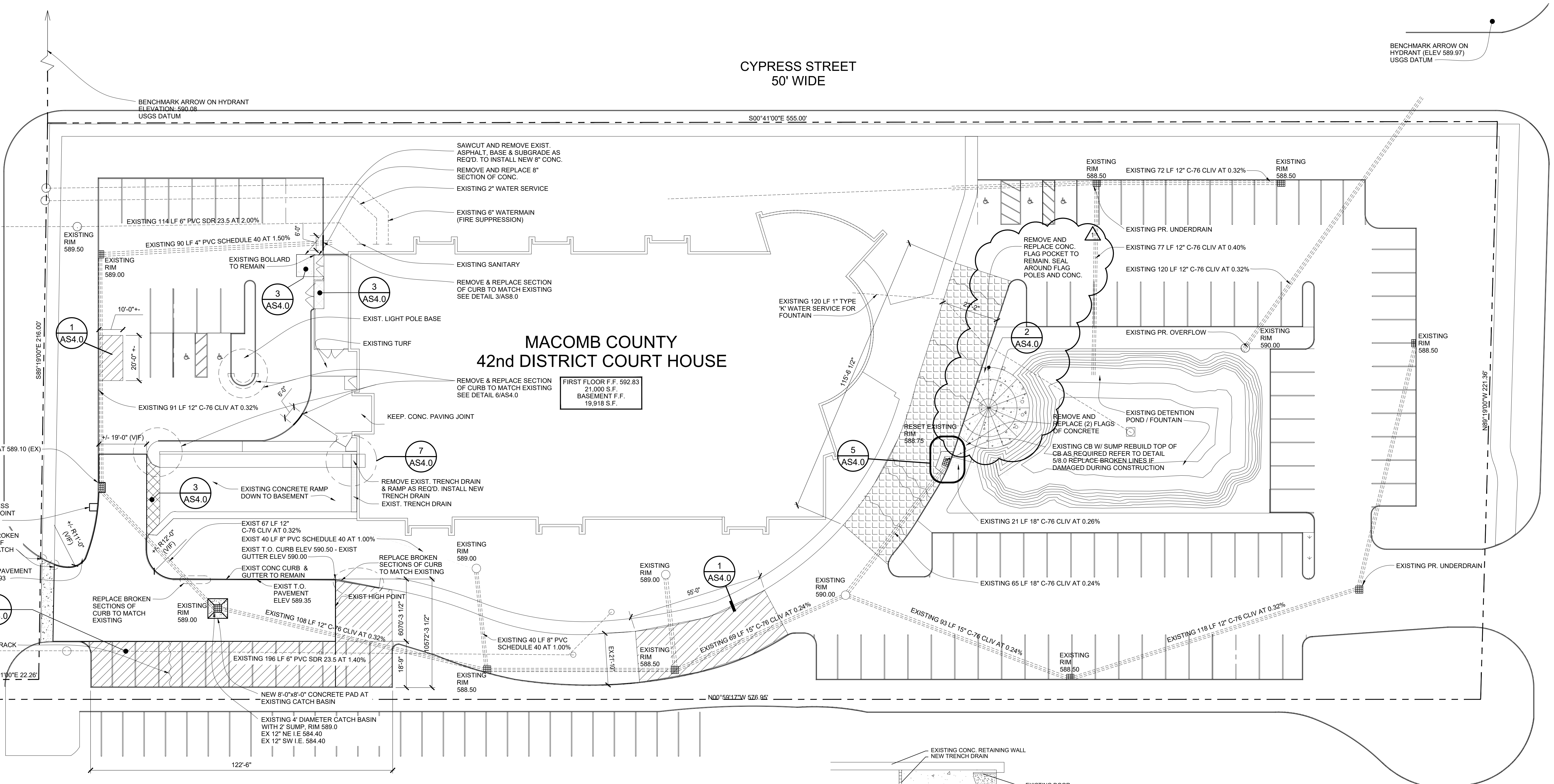
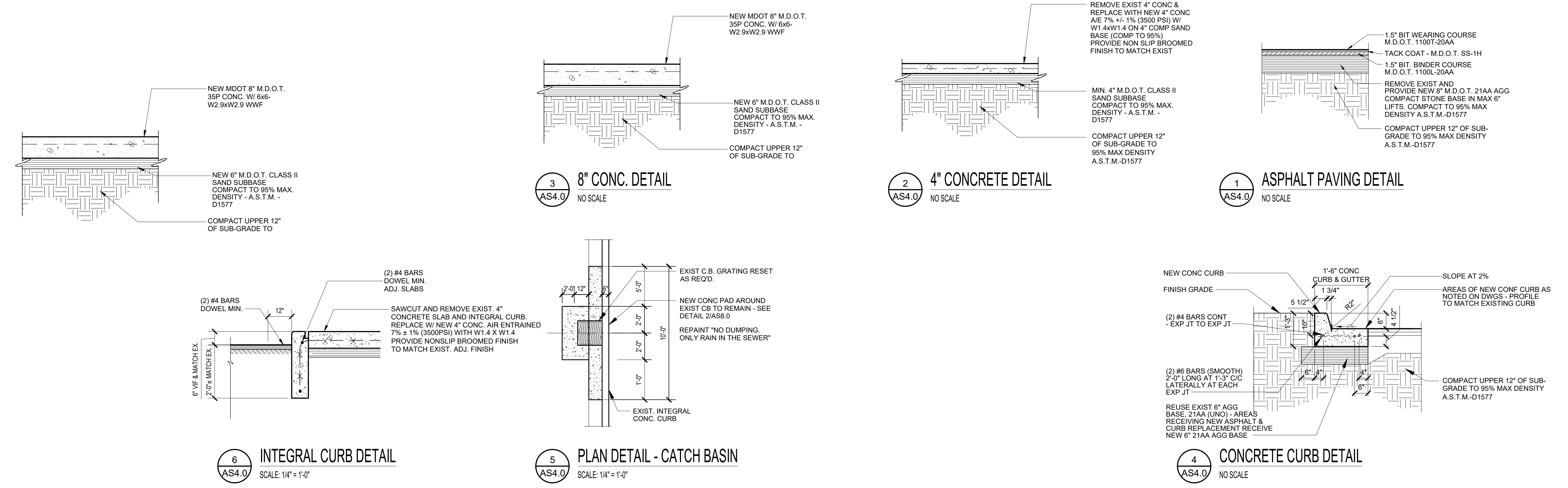

WA
WAKELY ASSOCIATES, INC.
ARCHITECTS & ENGINEERS

30500 VAN DYKE AVENUE
SUITE 209
WARREN, MICHIGAN 48093
PH: 586.573.4100
FX: 586.573.0822
EM: wo@wakelyia.com

**2024 MACOMB COUNTY PAVING
VARIOUS SITES**

42nd DISTRICT COURT
NEW BALTIMORE, MI
SITE PLAN & DETAILS

PRELIMINARY
DESIGN DEVELOPMENT
CONSTRUCTION
FINAL RECORD

DRAWN BY: JMS
CHECKED BY: RAS

REVISIONS:
ADDENDUM #1 JULY 22, 2024

DATE: JULY 1, 2024
SHEET NO.:

72 HOURS
(3 WORKING DAYS)
BEFORE YOU DIG
CALL MISS DIG
800-482-7171
(TOLL FREE)

AS4.0

JOB NO.: 242024